

Incremental encoders

Solid shaft with EURO flange B10

500...5000 pulses per revolution

POG 86



POG 86

Technical data - electrical ratings

Voltage supply	9...30 VDC 5 VDC \pm 5 %
Consumption w/o load	\leq 100 mA
Pulses per revolution	500...5000
Phase shift	90° \pm 20°
Scan ratio	45...55 % (40...60 % >3072 pulses per revolution)
Reference signal	Zero pulse, width 90°
Sensing method	Optical
Output frequency	\leq 170 kHz \leq 300 kHz (on request)
Output signals	K1, K2, K0 + inverted Error output (only EMS)
Output stages	HTL-P (power linedriver) TTL/RS422
Interference immunity	EN 61000-6-2
Emitted interference	EN 61000-6-3
Approvals	CE, UL/ CSA approval / E256710

Features

- Robust, compact housing
- Two bearings with large distance, one at each end
- High shaft load up to 350 N
- Shock resistant up to 300 g
- Highest operating speed 12000 rpm
- TTL output driver for cable length up to 550 m
- Terminal box, turn by 180°

Optional

- Function control with EMS
(Enhanced Monitoring System)

Technical data - mechanical design

Size (flange)	\varnothing 115 mm
Shaft type	\varnothing 11 mm solid shaft
Admitted shaft load	\leq 250 N axial \leq 350 N radial
Flange	EURO flange B10
Protection DIN EN 60529	IP 56
Operating speed	\leq 12000 rpm (mechanical)
Operating torque typ.	2 Ncm
Rotor moment of inertia	200 gcm ²
Materials	Housing: aluminium, coated Shaft: stainless steel
Operating temperature	-40...+100 °C -25...+100 °C (>3072 pulses per revolution)
Resistance	IEC 60068-2-6 Vibration 10 g, 10-2000 Hz IEC 60068-2-27 Shock 300 g, 1 ms
Corrosion protection	IEC 60068-2-52 Salt mist Complies to ISO 12944-5:1998 Protective paint systems (C4)
Explosion protection	II 3 G Ex nA IIC T4 Gc (gas) II 3 D Ex tc IIIB T135°C Dc (dust)
Connection	Terminal box
Weight approx.	1.4 kg

Subject to modification in technic and design. Errors and omissions excepted.

Incremental encoders

Solid shaft with EURO flange B10

500...5000 pulses per revolution

POG 86

Part number

Incremental encoder

POG 86

	T	N	1	DN			
--	---	---	---	----	--	--	--

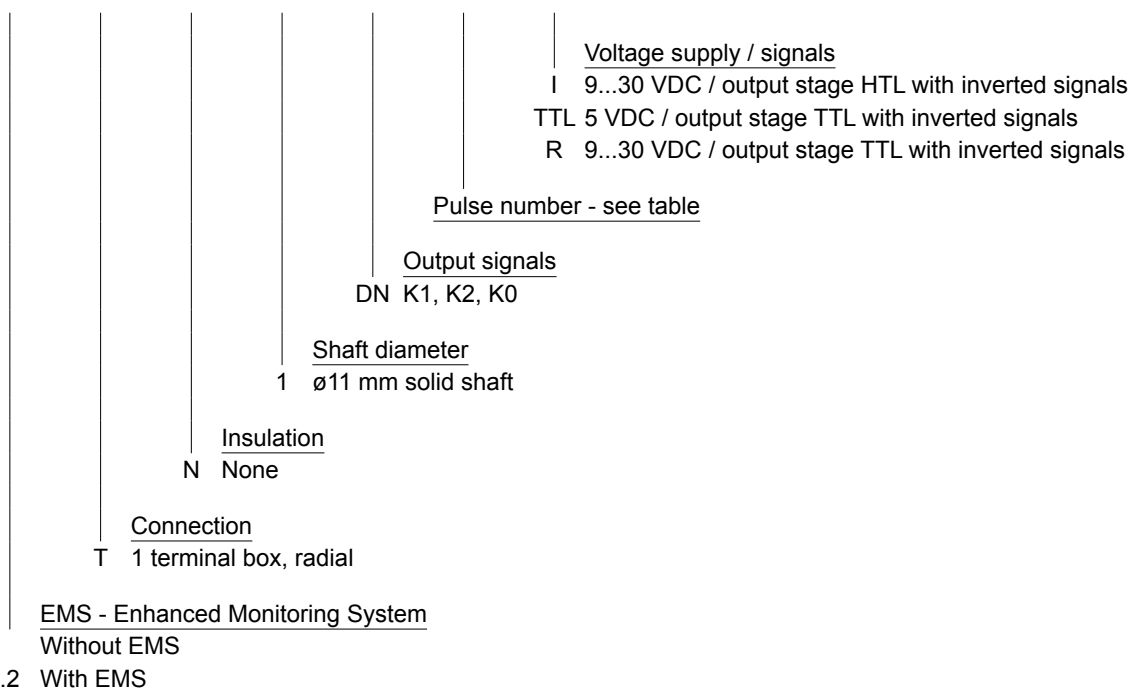

Pulse number

500	1000	1250	2500	4096
512	1024	2048	3072	5000

Other pulse numbers on request.

Accessories

Connectors and cables

HEK 8	Sensor cable for encoders
-------	---------------------------

Mounting accessories

K 35	Spring washer coupling for solid shaft ø6...12 mm
K 50	Spring washer coupling for solid shaft ø11...16 mm
K 60	Spring washer coupling for solid shaft ø11...22 mm

Diagnostic accessories

HENQ 1100	Analyzer for encoders
-----------	-----------------------

Subject to modification in technic and design. Errors and omissions excepted.

Incremental encoders

Solid shaft with EURO flange B10

500...5000 pulses per revolution

POG 86

Output signals

At positive rotating direction

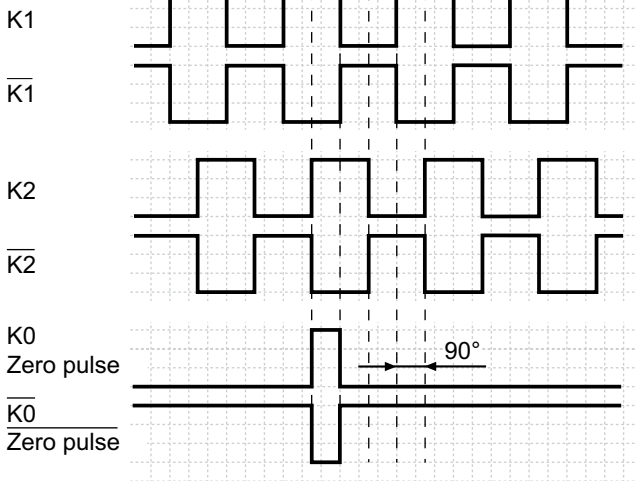

Terminal significance

+UB	Voltage supply (for the encoder)
⊥; ↓; GND; 0 V	Ground (for the signals)
⊥; ↘	Earth ground (chassis)
K1; A; A+	Output signal channel 1
K1̄; Ā; A-	Output signal channel 1 inverted
K2; B; B+	Output signal channel 2 (offset by 90° to channel 1)
K2̄; B̄; B-	Output signal channel 2 (offset by 90° to channel 1) inverted
K0; C; R; R+	Zero pulse (reference signal)
K0̄; C̄; R̄; R-	Zero pulse (reference signal) inverted
Err; Err-	Error output

Terminal assignment

View A

Connecting terminal terminal box

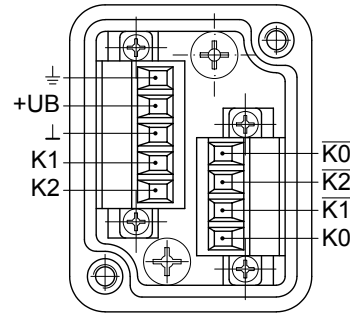

Option EMS: View A

Connecting terminal terminal box

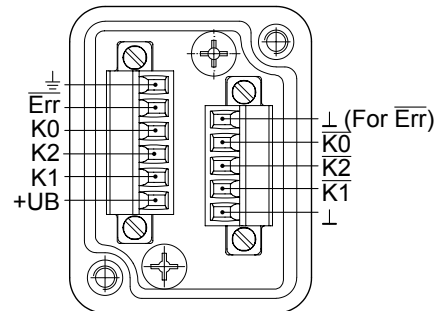

Option EMS: LED status / Error output

Flash light red*	Error of signal sequence, zero pulse or pulses (Error output = HIGH-LOW alternation)
Red	Overload output driver (Error output = LOW)
Flash light green	Encoder o.k., rotating (Error output = HIGH)
Green	Encoder o.k., stopped (Error output = HIGH)
No light	No output voltage connection or wrong connection (Error output = LOW)

* Only at rotating encoder

Incremental encoders

Solid shaft with EURO flange B10
500...5000 pulses per revolution

POG 86

Dimensions

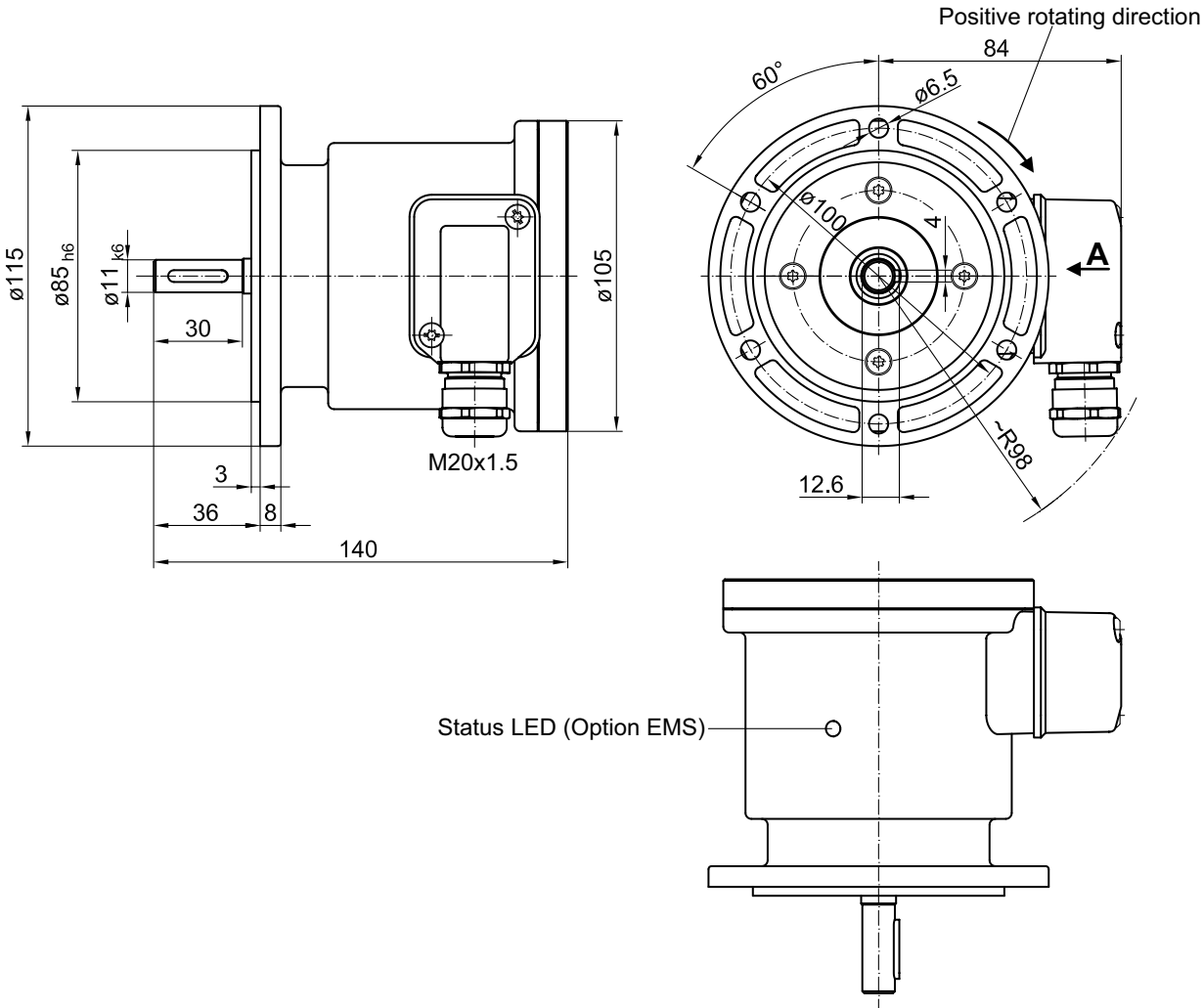

Subject to modification in technic and design. Errors and omissions excepted.